

## ZET-Horn 131/141 AC

The ZÖLLNER ZET-Horn was the first piston type whistle on the world market driven by an AC 3phase motor. An essential component is the piston inside the cylinder driven by an AC 3phase motor via connecting rod, crankshaft and gearwheels. The piston oscillates at a certain frequency which makes the air inside the sound projector vibrate in resonance to produce a sound audible over a wide range.

### Essential information:

- » full compliance with the COLREGS 1972, Annex III
- » type approved by all wellknown international authorities and classification societies
- » system voltage: AC 3phase/control box AC 1phase
- » entirely made of best non-corrosion, seawater resistant materials: gearwheels made of wear-resistant upgraded steel

### Application:

- » vessels of class II (75 m but less than 200 m in length)
- » land alarm, i.e. bunker stations, oil refineries, airports, power plants, factories

### Options:

- » rubber metals for vibration reduction
- » special design for arctic class available
- » special military design available

### Advantages:

- » decades of experience
- » best material and workmanship - made in Germany
- » simple but matured design: easy exchange of all parts with onboard tools, steady lubrication with standard grease (no oil!)
- » cylinder suspended vertically to allow optimum discharge of spray, flood, condensation water or melted snow
- » motor heating to avoid condensed water included as a standard - no additional cable required!

### Sound Characteristics

- » broad frequency spectrum with many higher harmonics
- » signals with strong overtones for best penetration of background noise level: Even when a background noise covers the actual basic frequency the residual tone forms a parent frequency in the human hearing. Two or three harmonics are sufficient for the hearing to perceive the basic frequency.
- » sound frequency of 130 Hz / 140 Hz very advantageously ranks in the lower admissible range (130-350 Hz)
- » sound pressure level 138 dB in 1/3rd octave band at 1 m distance

### Easy installation:

- » only one three-core cable required for connection to board mains
- » relatively low weight
- » not affected by voltage and frequency fluctuations of board mains



## Technical information

### Positioning and installation

Positioning as high as practicable on the vessel to reduce interception of the emitted sound by obstructions and to avoid hearing damage risk to the personnel. The sound pressure level of a vessel's own signal at listening posts must not exceed 110 dB(A).

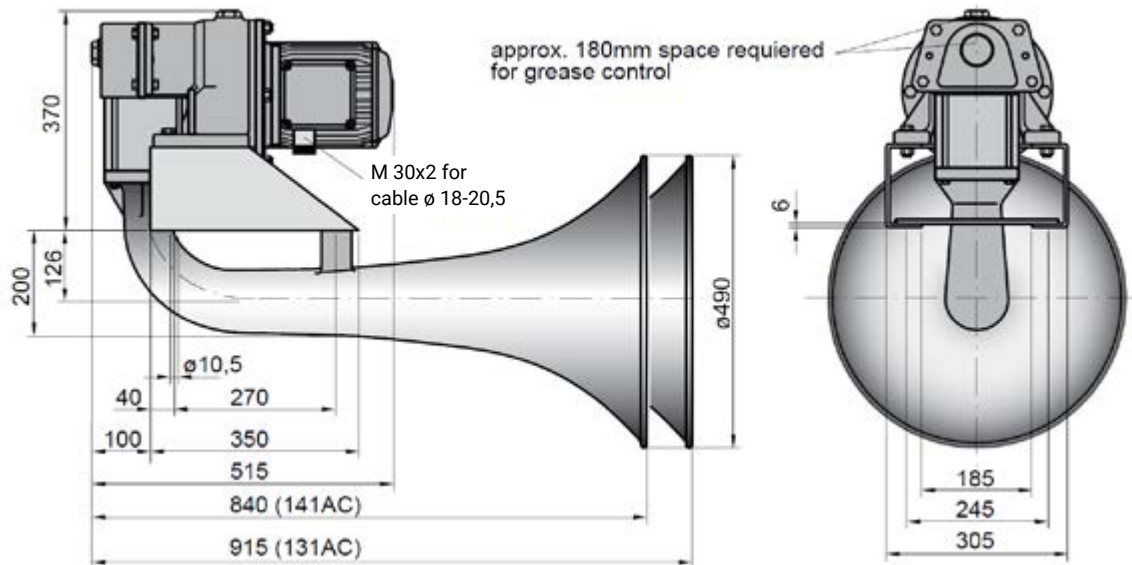

141AC weight approx. 62 kg  
131AC weight approx. 62 kg

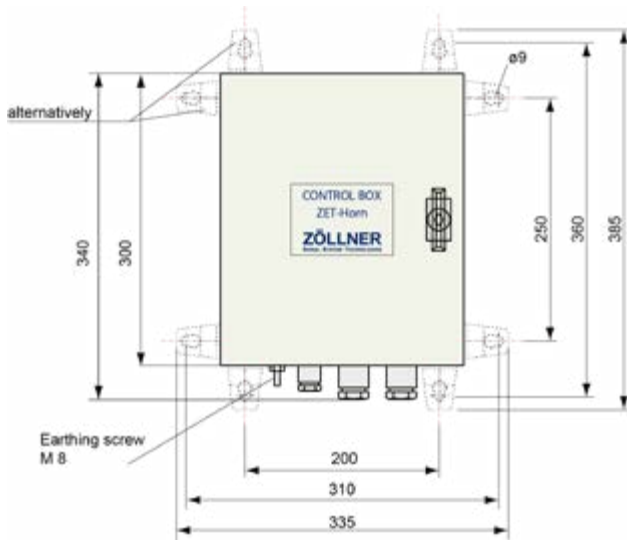

drawing 01415158

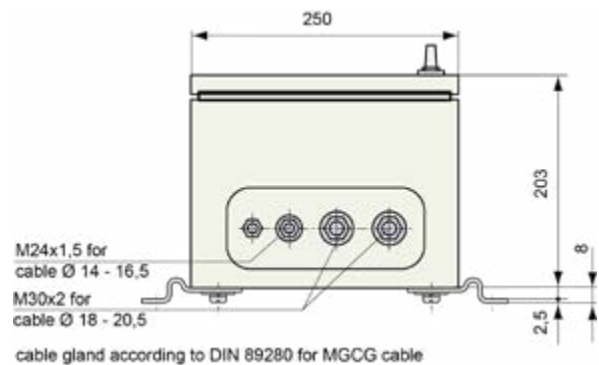

Standard control box  
(supply voltage 380 / 440 V - control voltage 115 / 220 V)  
- other voltages on request  
weight approx. 8,7 kg

TYPE	SHIP LENGTH	FUNDAMENTAL FREQUENCY	SOUND INTENSITY IN 1/3RD-OCT. BAND LEVEL AT 1 M (MIN. 138 DB ACC. TO IMO)	TYPE APPROVAL	MOTOR OUTPUT	MOTOR HEATING	PROTECTION TYPE
141AC	75- <200 m	140 Hz	138 dB	✓	5,5 kW	100 W	IP 56
131AC	75- <200 m	130 Hz	138 dB	✓	5,5 kW	100 W	IP 56